

地板螺絲位置

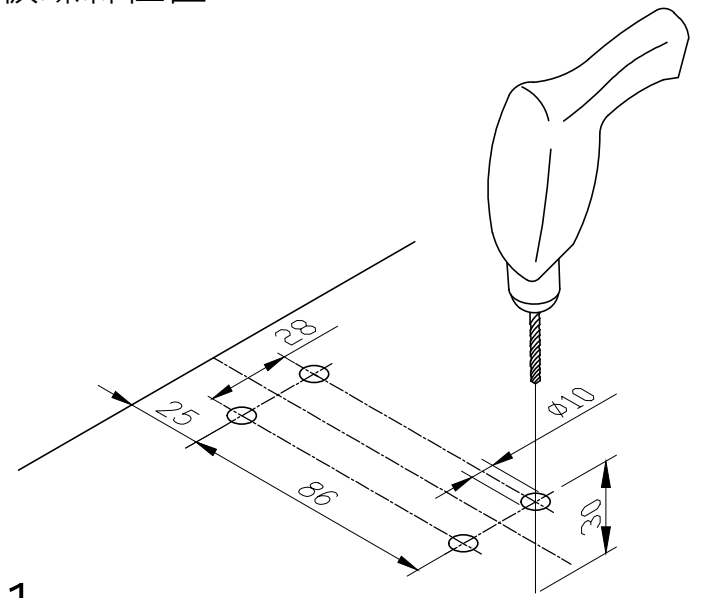

b1

置入膨脹螺絲

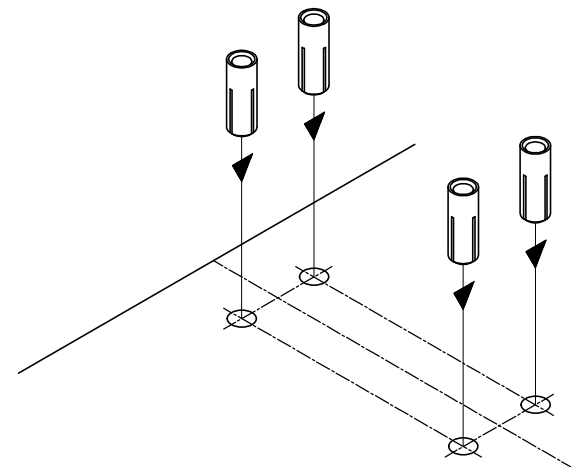

b2

底座鎖上螺絲

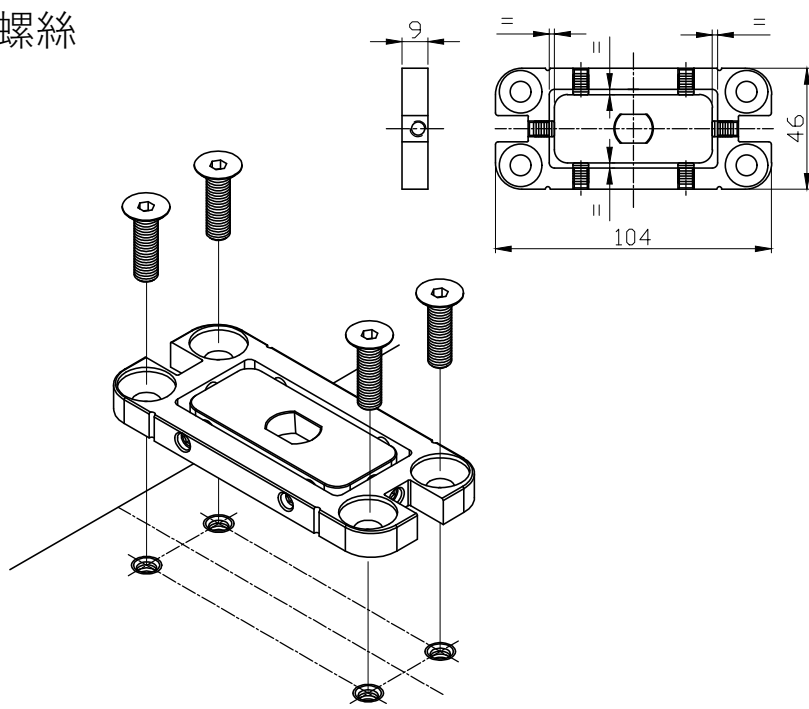

b3

對準底座軸芯置入本體

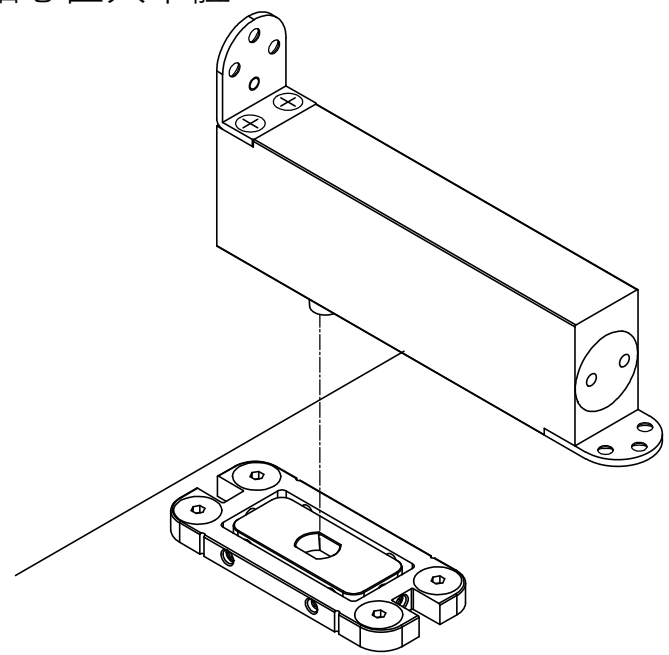

b4

將本體轉向(如圖示)

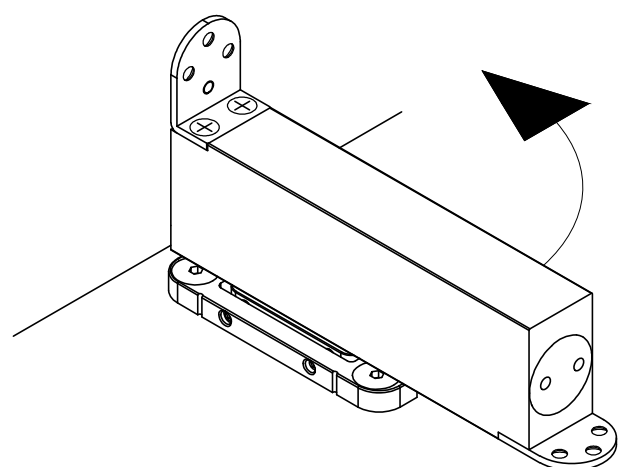

b5

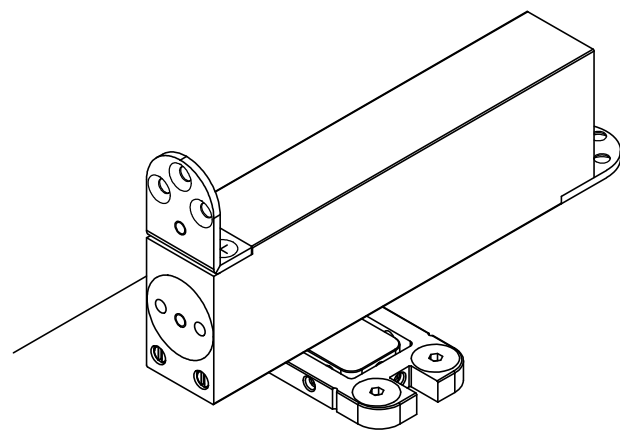

b6

